



Taiko Device Techno & Co., Ltd. RTC1 RELAY SPECIFICATION

All data are at 20°C ambient temperature unless otherwise noted.

Miniature high current PCB relay.

Covers a broad range of automotive applications.

The relays are lead free / RoHS compliant.

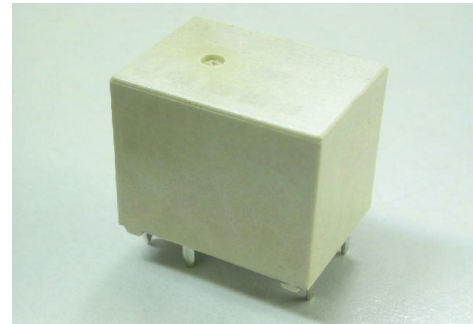

RTC1

Available Standard Types

RTC1	Reflow Type	reflow solderable	125°C	max. ambient temperature
------	-------------	-------------------	-------	--------------------------

* The standard "R" types have a vent-hole in the cover (Letter T appended)

Special Features available: (see nomenclature page)

Available Coil Options

Coil Resistance	Coil Inductance	Nominal Power	Operate Voltage	Operate Power	Release Voltage
160 Ω	376 mH	0.900 W	6.5 V	0.264 W	0.5 V
110 Ω	265 mH	1.309 W	5.5 V	0.275 W	0.5 V
225 Ω	506 mH	0.640 W	7.7 V	0.264 W	0.5 V

ITEM	SPECIFICATION
Contact Arrangement	1 Form C / 1 Form A / 1 Form U (double-make contact)
Contact Material	AgSnO ₂ Alloy
Contact Resistance	Typical 3 mΩ (max 50mΩ at 6 VDC 1A)
Contact Rated Load	25A at 14VDC Motor load (Locked Rotor)
Max. Switching Current/ Voltage	30A at 16VDC
Max. Continuous Current at 20 °C	30A at 14VDC for 10minutes
Min. Switching Current (recommended)	1A at 12VDC
Dielectric Strength	500VAC for 1 minute (between coil and contact)
	500VAC for 1 minute (between open contacts)
Insulation Resistance	Min 100MΩ (at 500VDC)
Operate Time	typical 4 ms (at 12VDC/ 20)
Release Time	typical 2 ms with no diode parallel to coil
Shock resistance	False Operation
	Endurance
Vibration resistance	False Operation
	Endurance
Mechanical Life (no load)	Min 10×10 ⁶ Operations(300 cycles/minute)
Electrical Life at rated load	Min 0.1×10 ⁶ Operations(1 sec. ON/ 9 sec. OFF)
Ambient Temperature range	-40°C to 125°C max.,Max 85%RH
Weight	Approx. 10g

Taiko Device Techno & Co., Ltd. RTC1 RELAY SPECIFICATION

All data are at 20°C ambient temperature unless otherwise noted.

TECHNICAL REFERENCE DATA FOR THE RTC1-160 RELAY

Contact Resistance of the N/O contact	Contact Resistance of the N/C contact
---------------------------------------	---------------------------------------

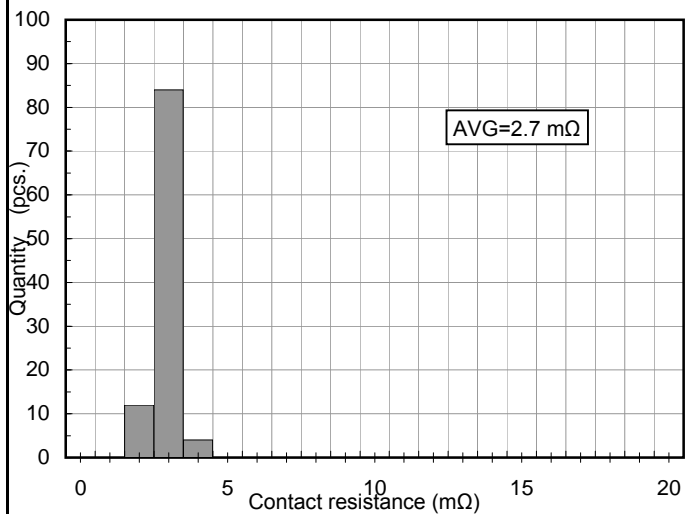
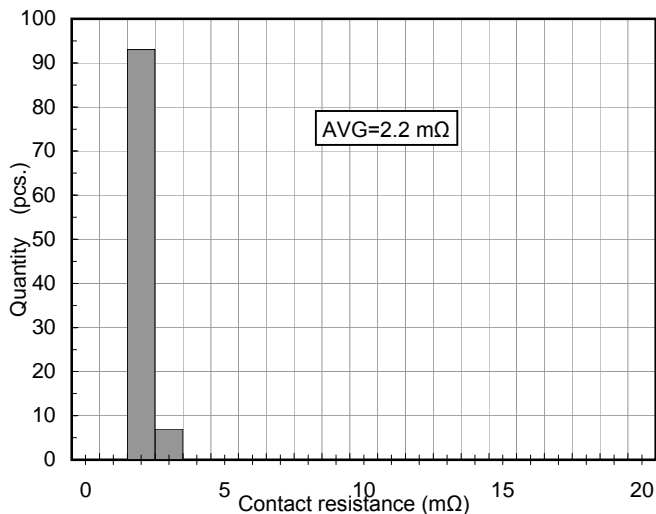

Operate Time	Release Time
--------------	--------------

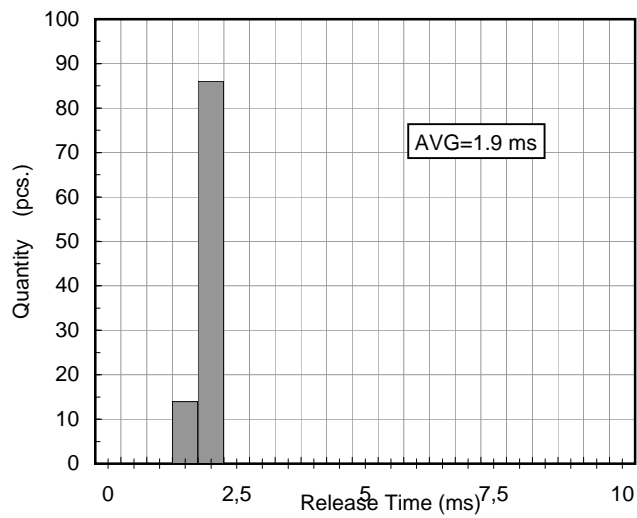
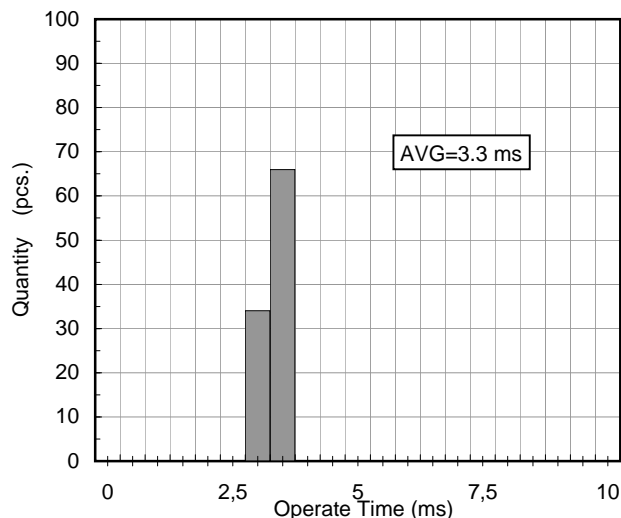

Operating Voltage Range of the RTC1 with a 160 Ω coil

Please note, that this diagram shows the Operate Voltage range for coil at ambient temperature and the Maximum Voltage is either 16 V or the voltage that over time brings the coil to the max. allowed temperature. No Load Current considered.

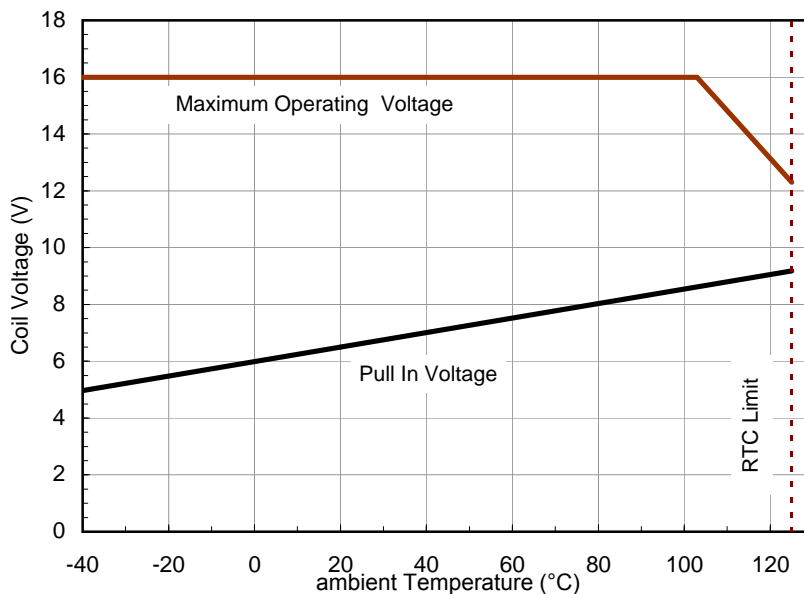

Taiko Device Techno & Co., Ltd. RTC1 RELAY SPECIFICATION

All data are at 20°C ambient temperature unless otherwise noted.

TECHNICAL REFERENCE DATA FOR THE RTC1-160 RELAY

Coil temperature rise of the RTC1 with 160 Ω coil

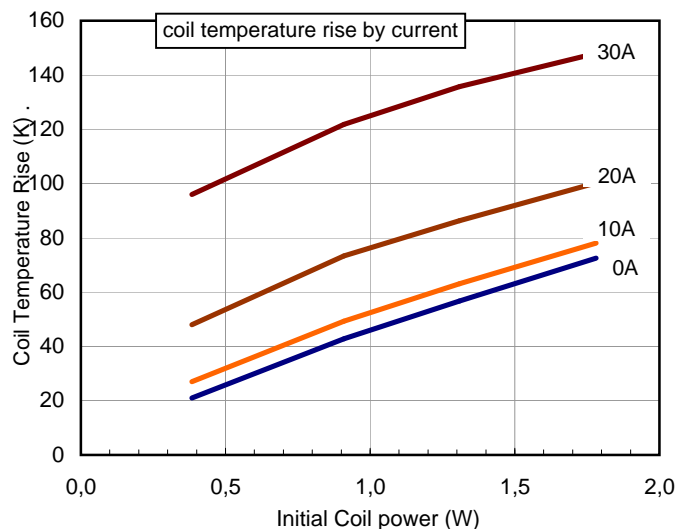
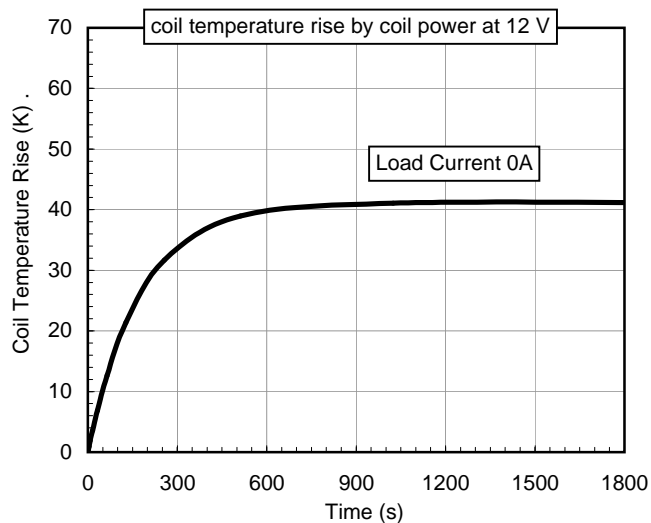

Over current limit

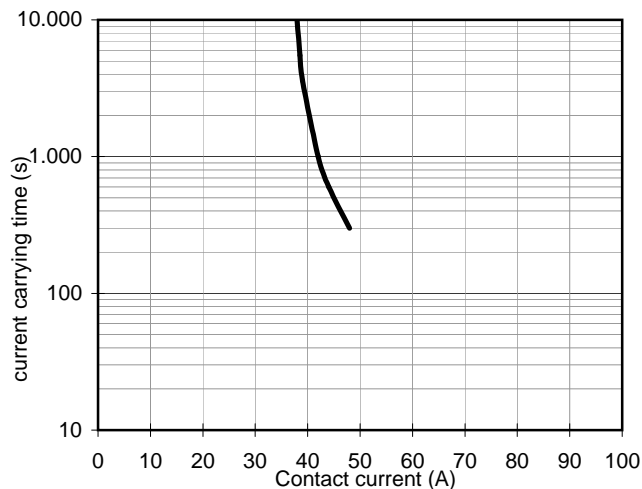

Operate and Release time

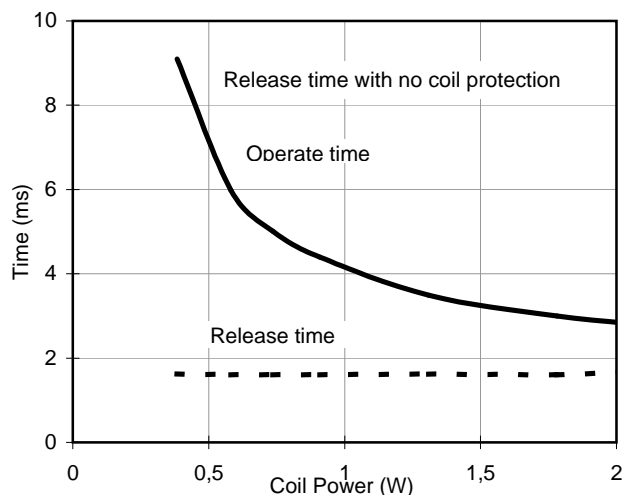

Contact voltage drop

- increasing current
- - - decreasing current

This diagram shows the voltage drop over current for the NO contact during the increase of the current and during the decrease

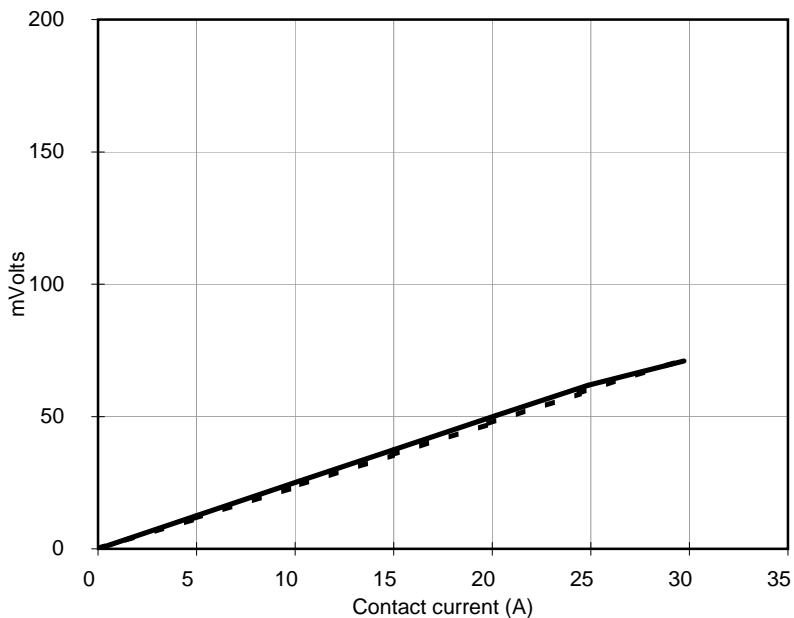

Taiko Device Techno & Co., Ltd. RTC1 RELAY SPECIFICATION

All data are at 20°C ambient temperature unless otherwise noted.

External Dimensions / Wiring Diagram / PCB Pin Layout

Fig.1 : External Dimensions

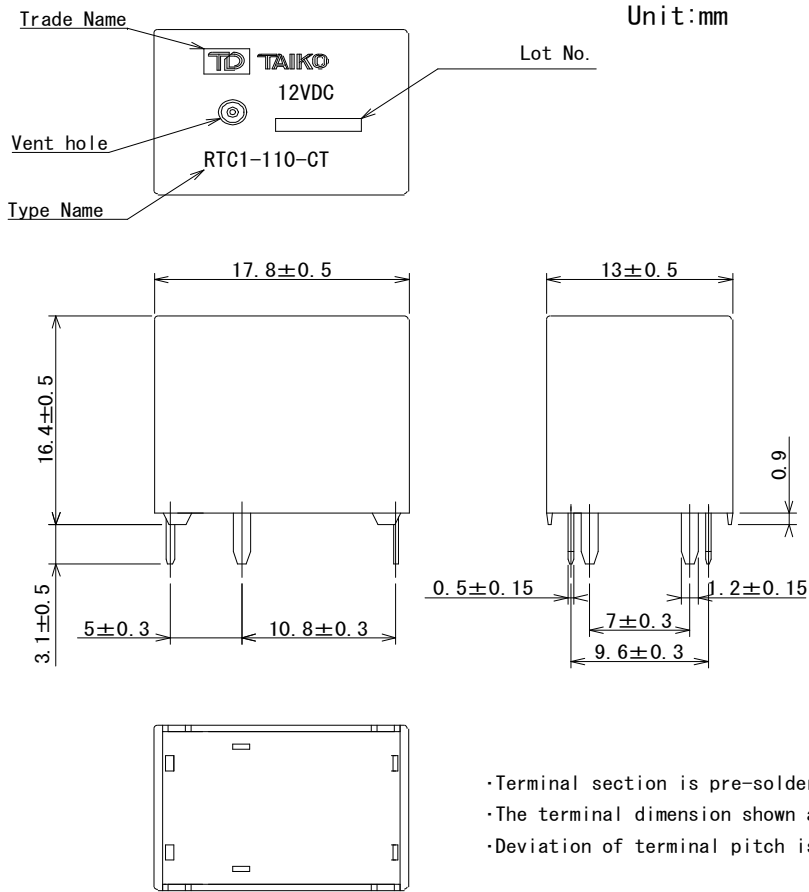

Fig.2. Wiring diagram (BOTTOM VIEW)

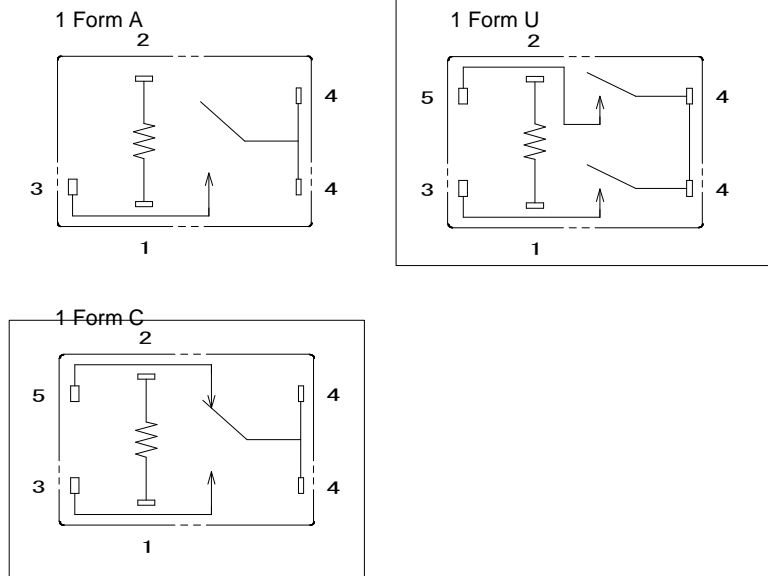
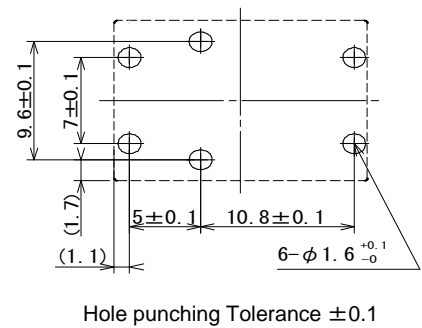

Fig.3. PCB pin layout(Reference figure) (BOTTOM VIEW)



Taiko Device Techno & Co., Ltd.
RTC1 RELAY SPECIFICATION

All data are at 20°C ambient temperature unless otherwise noted.

Packaging specification

Standard Tube Packaging

50 relays per tube, 20 tubes per box (1000 relays per box)

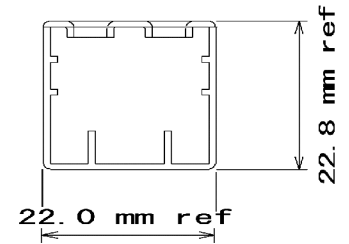
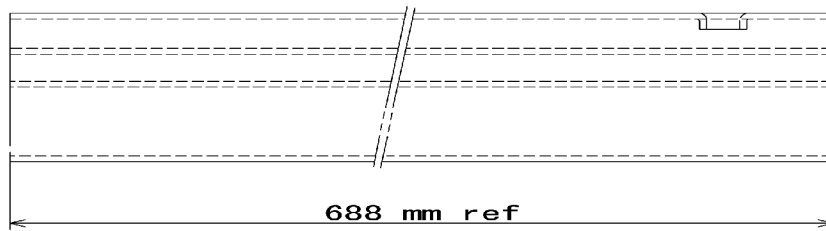

Notes:

For further information, please contact Taiko device Techno.

Disclaimer:

The above information is for information only and with no responsibility, not binding and can be changed any time.
Taiko Device Techno cannot be held responsible for typos, or misprints.