

Flat miniature power single SMD PCB relay
Volume 69%, height 65%, compared to our TB relay.
Covers a broad range of automotive applications.

The relays are lead free / RoHS compliant.

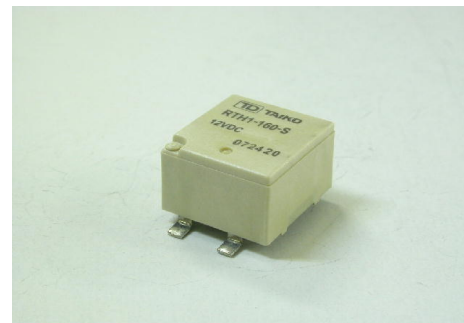

RTH1

Available Standard Types

RTH1	Standard Type	Reflow solderable	125°C	max. ambient temperature
* The standard "R" types have a vent-hole in the cover (Letter T appended)				
Special Features available: (see nomenclature page)				

Available Coil Options

Coil Resistance	Coil Inductance	Nominal Power	Operate Voltage	Operate Power	Release Voltage
160 Ω	160 mH	0.900 W	6.5 V	0.264 W	0.6 V
220 Ω	214 mH	0.655 W	7.7 V	0.270 W	0.6 V

±10%

ITEM		SPECIFICATION
Contact Arrangement		1 Form C(RTH1,SMD type)
Contact Material		AgSnO ₂ Alloy
Contact Resistance		Max 50m Ω at 6 VDC 1A (5mΩ Typical)
Contact Rated Load		25 A at 14VDC Motor load (Locked Rotor)
Max. Switching Current/ Voltage		30A at 16VDC
Max. Continuous Current at 20 °C		25A at 14VDC for 10 minutes
Min. Switching Current (recommended)		1A at 12VDC
Dielectric Strength		500VAC for 1 minute (between coil and contact) 500VAC for 1 minute (between open contacts)
Insulation Resistance		Min 100M Ω (at 500VDC)
Operate Time		Max 10ms (at 12VDC, 20°C)
Release Time		Max 10ms (at 12VDC, 20°C)
Shock resistance	False Operation	Min 98m/s ² (10G) :Shock wave 11ms
	Endurance	Min 980m/s ² (100G) :Shock wave 6ms
Vibration resistance	False Operation	Min 43m/s ² (4.4G) at 10 to 500Hz
	Endurance	Min 43m/s ² (4.4G) at 10 to 500Hz
Mechanical Life (no load)		Min 10×10 ⁶ Operations(300 cycles/minute)
Electrical Life at rated load		Min 1.0×10 ⁵ Operations(1 sec. ON/ 9 sec. OFF)
Ambient Temperature range		-40°C to 125°C ,Max 85%RH
Weight		Approx. 3g

TECHNICAL REFERENCE DATA FOR RTH1-160

Contact Resistance

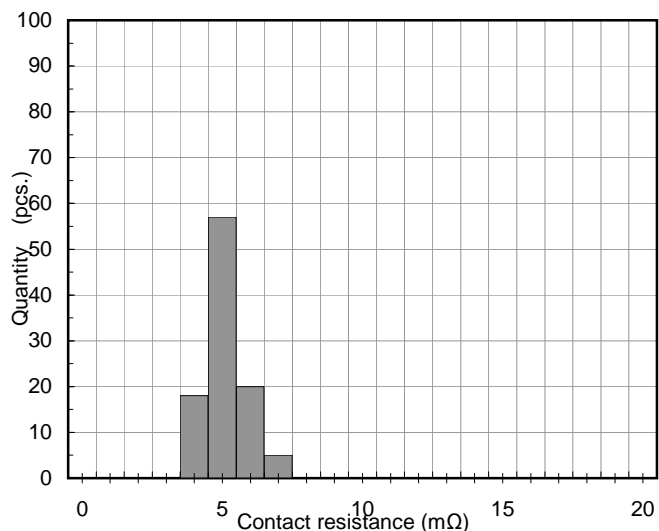
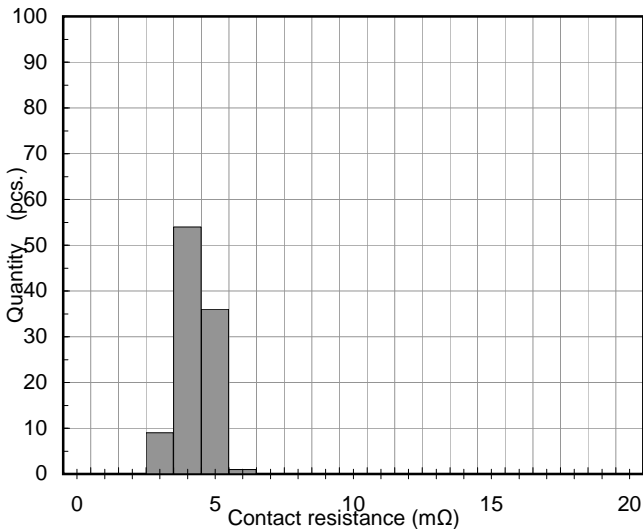

Operate Time of the RTH1 with 160 Ω coil

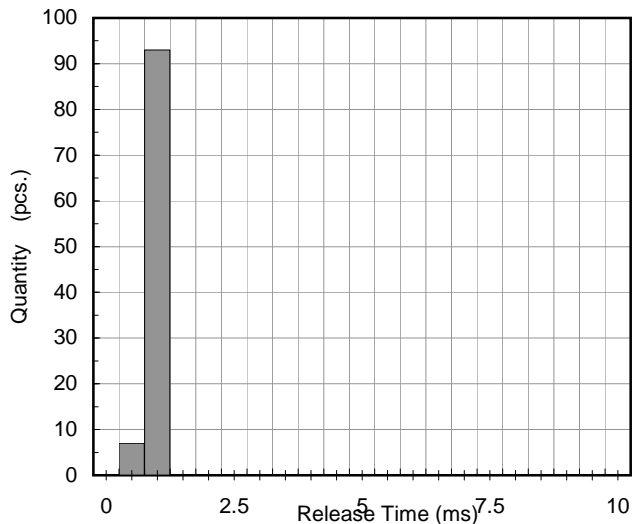
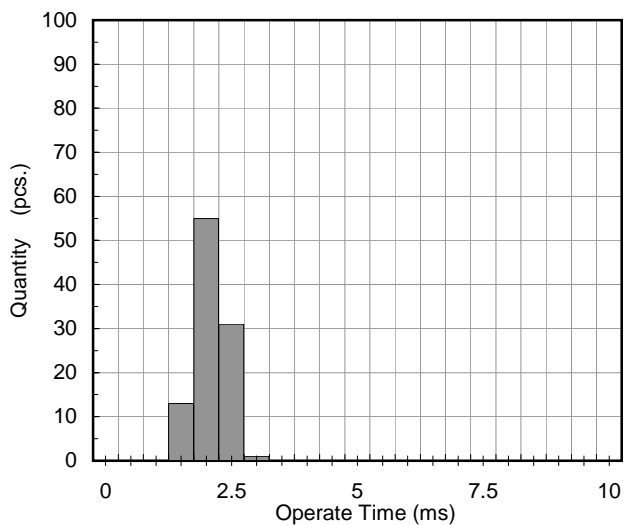

Operating Voltage Range of the RTH1 with a 160 Ω coil

Please note, that this diagram shows the Pull In Voltage range for coil at ambient temperature

and the Maximum Voltage is either 16 V or the voltage that over time brings the coil to the max. allowed temperature.

No Load Current considered.

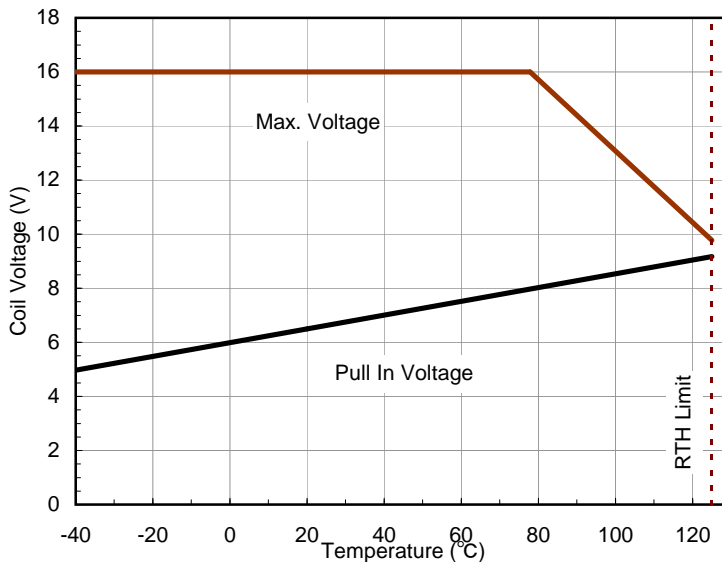

TECHNICAL REFERENCE DATA FOR RTH1-160

Coil temperature rise of the RTH1 with 160 Ω coil

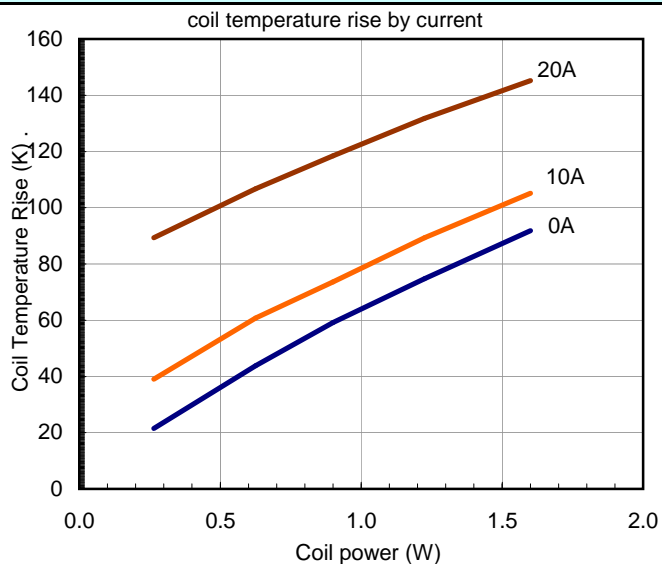
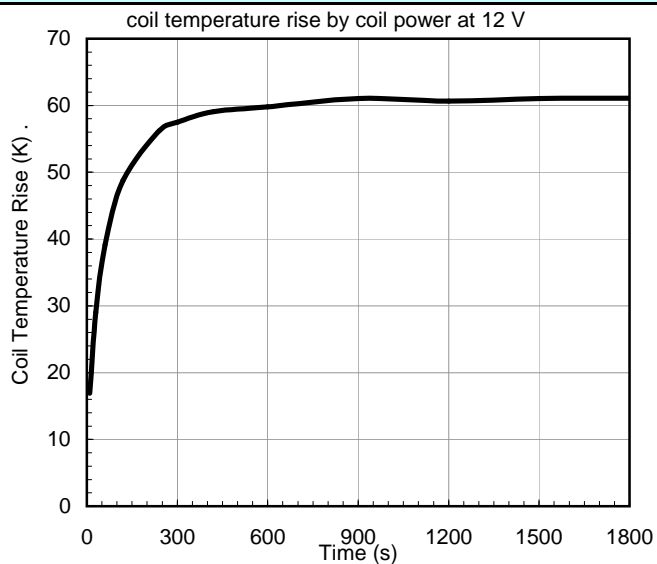

Over current limit of the RTH1-160

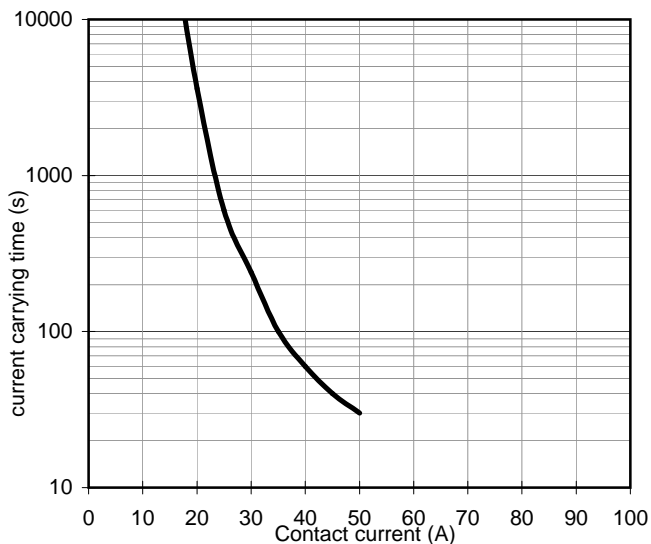

Operate and Release Time of the RTH1-160

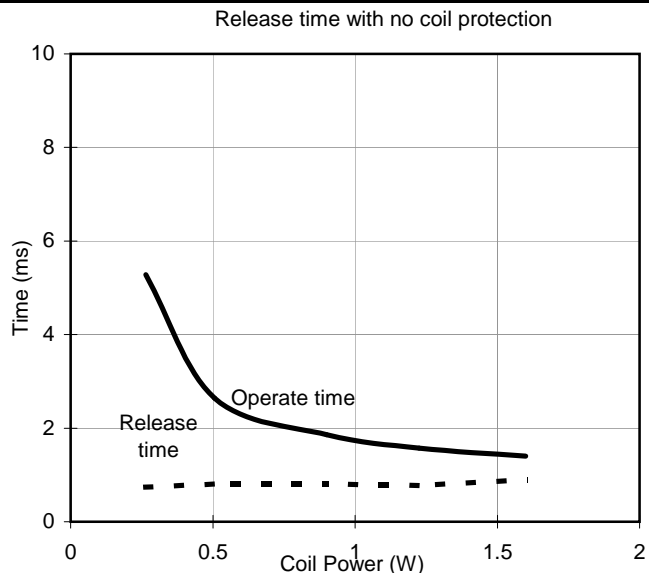

Contact voltage drop over the NO contact of the RTH1-160

— increasing current
- - - decreasing current

This diagram shows the voltage drop over current for the NO contact during the increase of the current and during the decrease

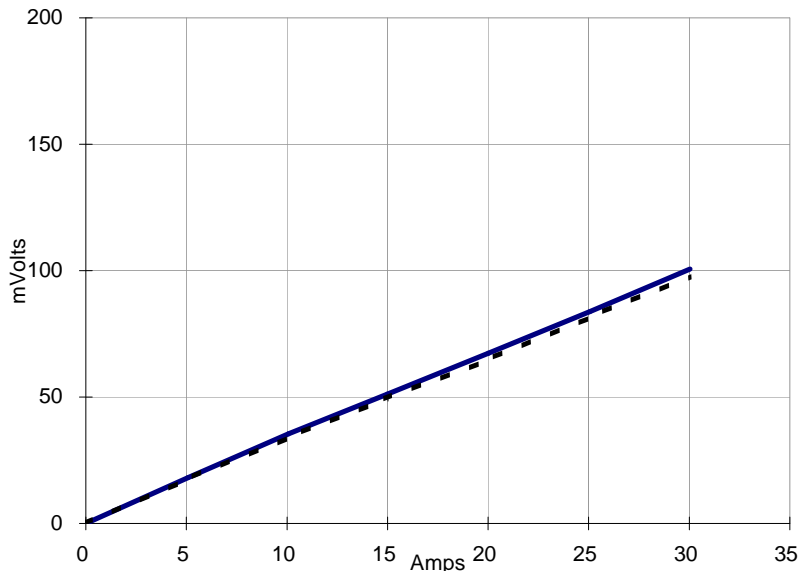

RTH1

Fig1. External dimensions

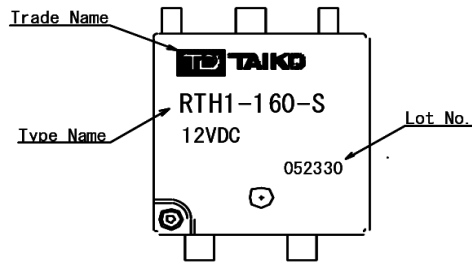

Unit : mm

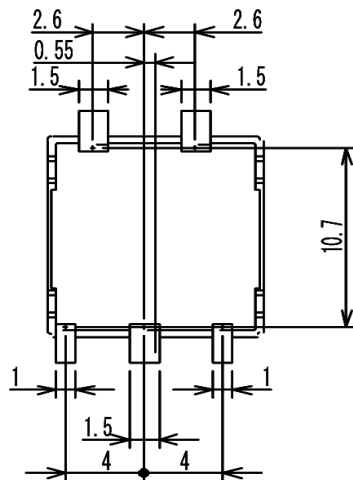
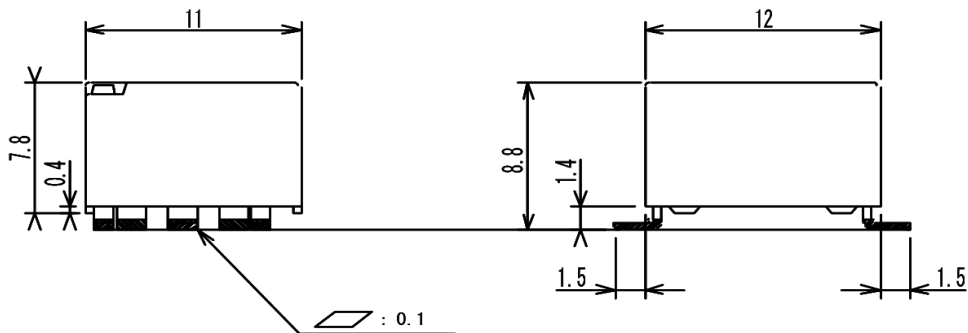

- Tolerance of terminal pitch is ± 0.3 at root of terminal.
- Terminal section is pre-soldered.
- External dimension tolerance

1mm or less	± 0.1 mm
1~3mm	± 0.3 mm
3mm or more	± 0.5 mm

Fig.2. Wiring diagram (BOTTOM VIEW)

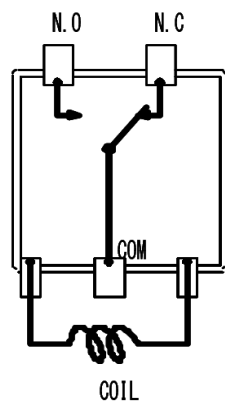
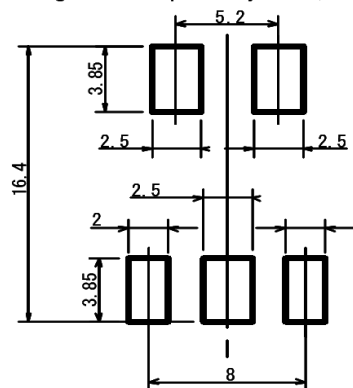

Fig.3. PCB pin layout (Reference figure)



Packaging specification

Standard : Tape and Reel

500 relays per reel

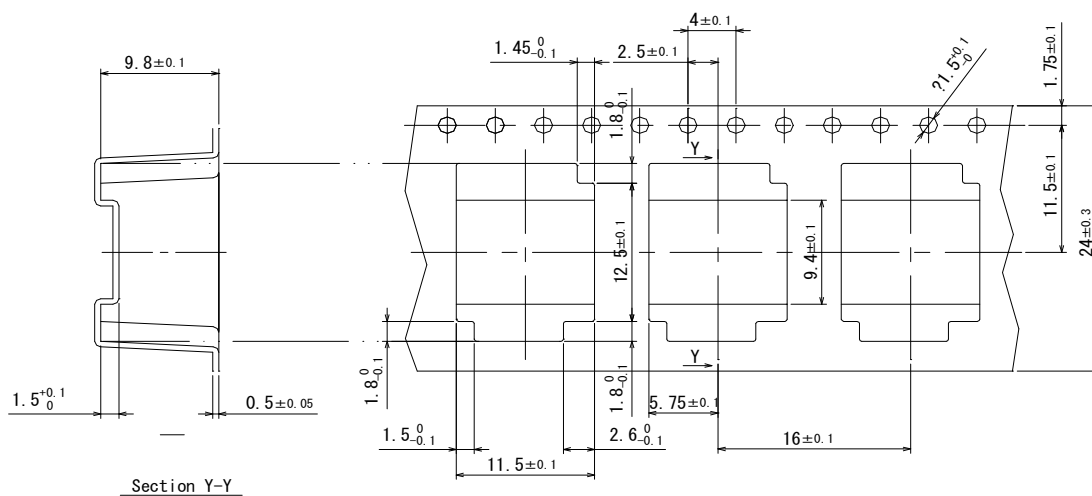

Note. Detail of reel center (groove of key shape)

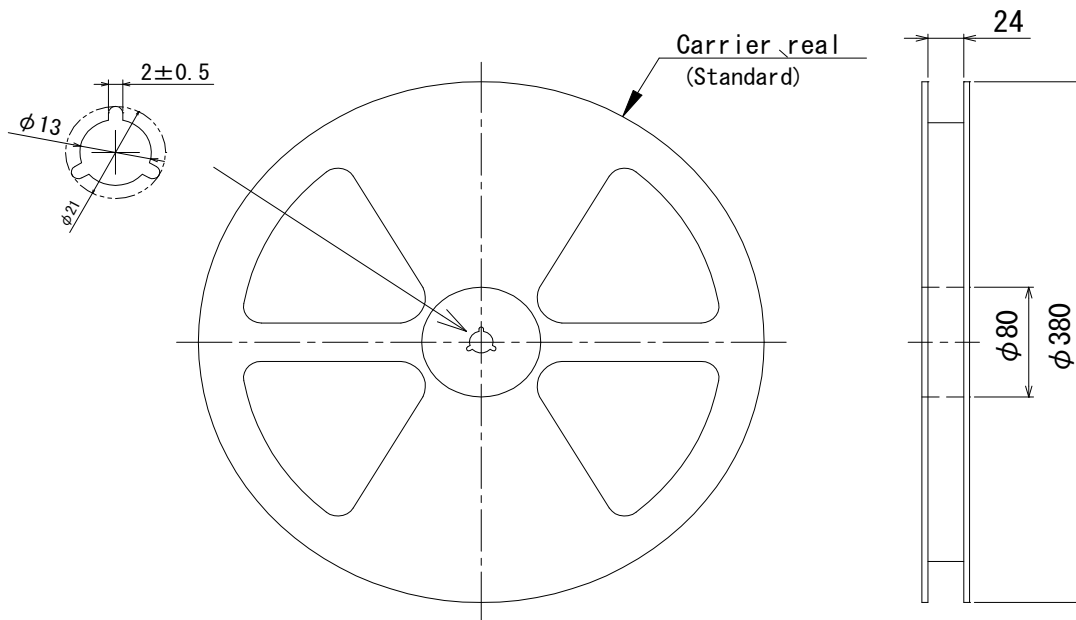

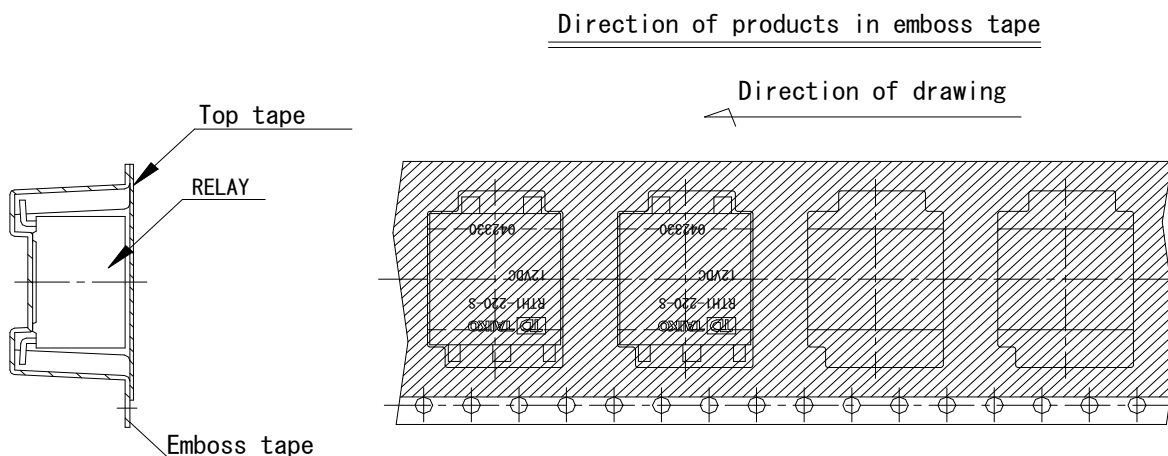

Breaking away strength of cover tape
 $0.6 \pm 0.35N$
 <Breaking away speed : $300 \pm 10mm/min$ >

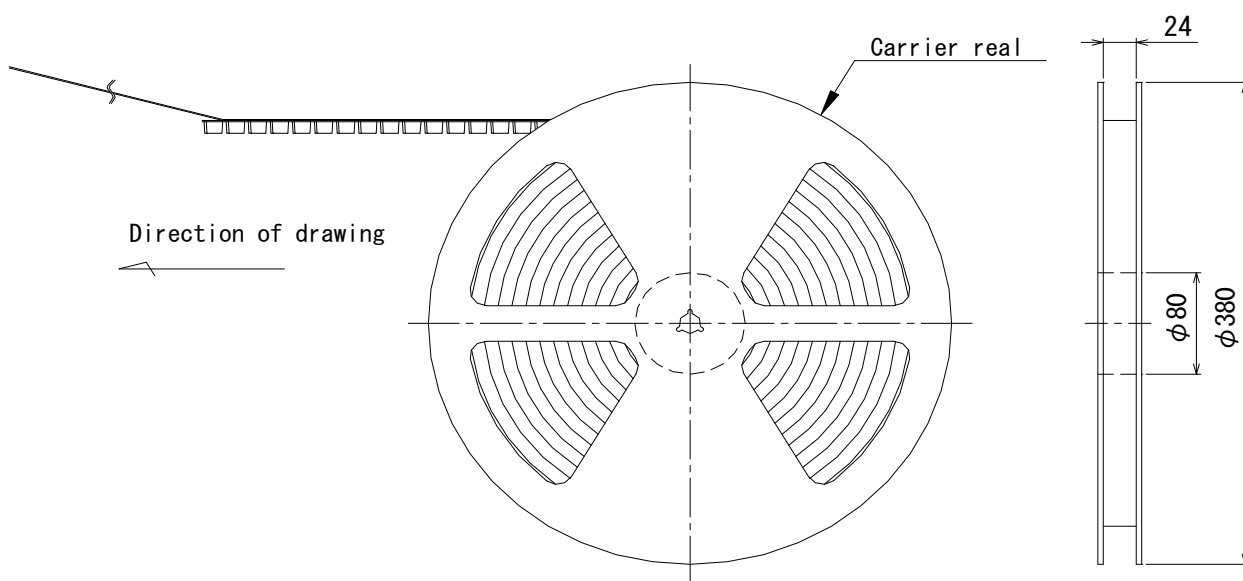
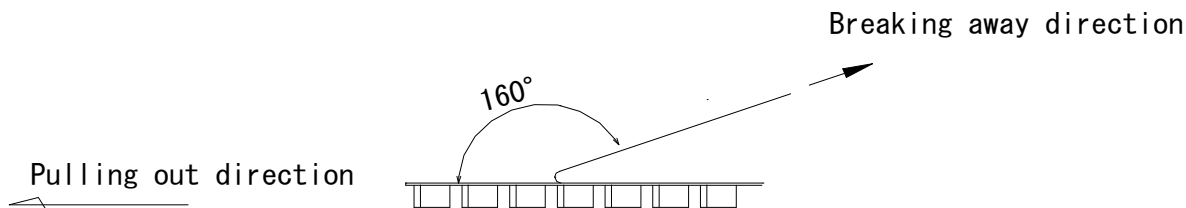

Notes:

For further information, please contact Taiko device Techno.

Disclaimer:

The above information is for information only and with no responsibility, not binding and can be changed any time.
 Taiko Device Techno cannot be held responsible for typos, or misprints.