

All data are at 20°C ambient temperature unless otherwise noted.

Miniature High Power PCB relay  
for motor reverse applications.

Covers a broad range of  
automotive applications.

The relays are lead free / RoHS compliant.

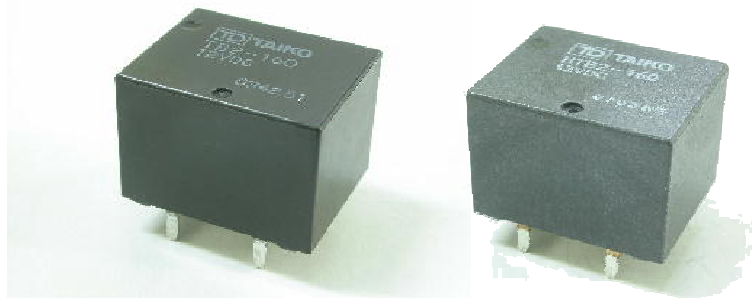

**TB2**

**HTB2**

**Available Standard Types**

TB2	Standard Type	wave solderable	85°C	max. ambient temperature
HTB2	High Temperature	wave solderable	125°C	max. ambient temperature

H-Bridge is standard without any additional letter  
The double relays version is marked with an appended letter "Z"  
Special Features available: ( see nomenclature page)

**Available Coil Options**

Coil Resistance	Coil Inductance	Nominal Power	Operate Voltage	Operate Power	Release Voltage
160 Ω	227 mH	0.900 W	6.5 V	0.264 W	0.8 V
100 Ω	143 mH	1.440 W	5.5 V	0.303 W	0.5 V
225 Ω	310 mH	0.640 W	7.7 V	0.264 W	0.8 V

±10%

ITEM		SPECIFICATION
Contact Arrangement		H-bridge or Double Relay ( 2 x 1C )
Contact Material		AgSnO <sub>2</sub> Alloy
Contact Resistance		Typical 4 mΩ (max 50mΩ at 6 VDC 1A)
Contact Rated Load		25A at 14VDC Motor load (Locked Rotor)
Max. Switching Current/ Voltage		30A at 16VDC
Max. Continuous Current at 20 °C		25A at 14VDC for 10minutes
Min. Switching Current (recommended)		1A at 12VDC
Dielectric Strength		500VAC for 1 minute (between coil and contact) 500VAC for 1 minute (between open contacts)
Insulation Resistance		Min 100MΩ (at 500VDC)
Operate Time		typical 3 ms (at 12VDC/ 20 °C)
Release Time		typical 1.5 ms with no diode parallel to coil
Shock resistance	False Operation	Min 98m/s <sup>2</sup> ( 10G ) :Shock wave 11ms
	Endurance	Min 980m/s <sup>2</sup> (100G) :Shock wave 6ms
Vibration resistance	False Operation	Min. 45m/s <sup>2</sup> ( 4.6G) at 10 to 500Hz
	Endurance	
Mechanical Life (no load)		Min 10×10 <sup>6</sup> Operations(300 cycles/minute)
Electrical Life at rated load		Min 1.0×10 <sup>5</sup> Operations(1 sec. ON/ 9 sec. OFF)
Ambient Temperature range		-40°C to 85°C (125°C max. for -H types) ,Max 85%RH
Weight		Approx. 9.5g

# Taiko Device Techno & Co., Ltd. TB2/HTB2 RELAY SPECIFICATION

All data are at 20°C ambient temperature unless otherwise noted.

## TECHNICAL REFERENCE DATA FOR THE TB2-160 AND HTB2-160 RELAY

### Contact Resistance of the N/O contact

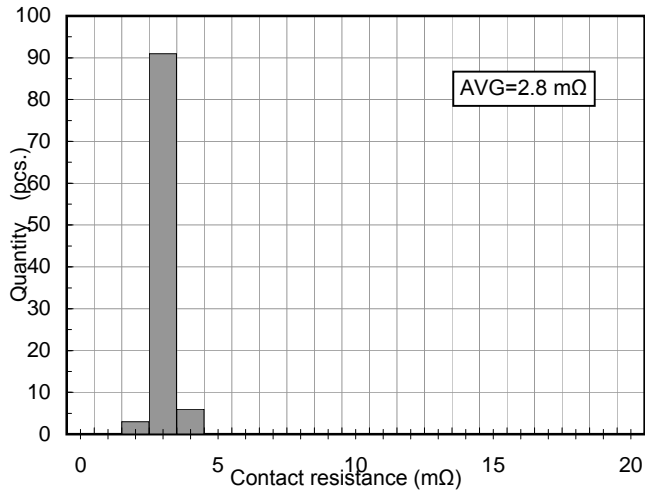

### Contact Resistance of the N/C contact

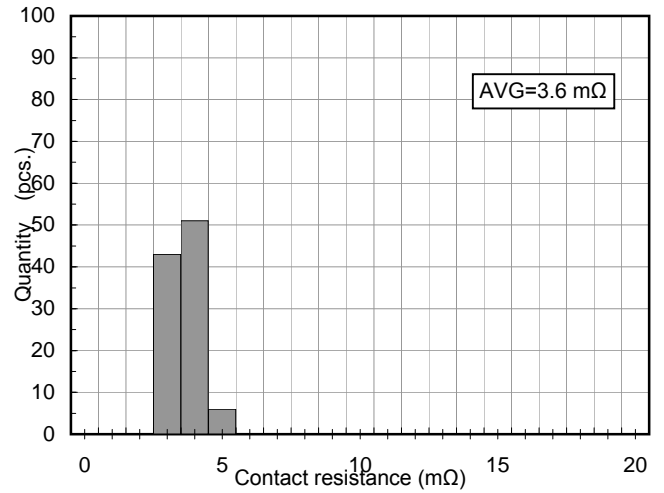

### Operate Time with 12 V

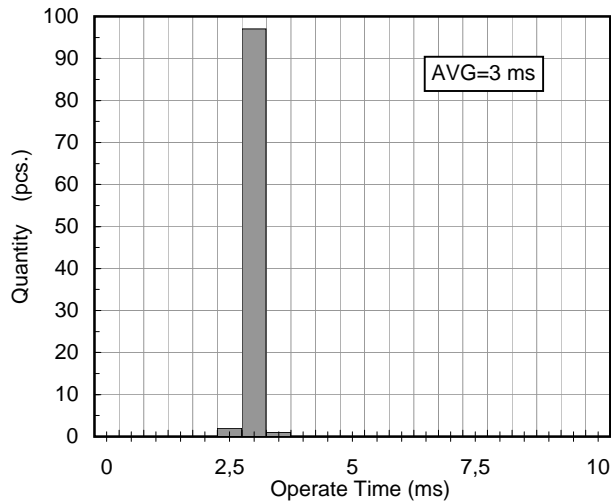

### Release Time without diode

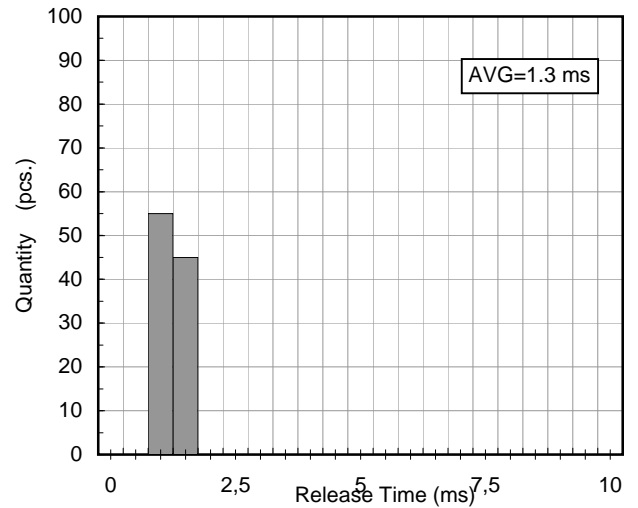

### Operating Voltage Range

Please note, that this diagram shows the Pull In Voltage range for coil at ambient temperature and the Maximum Voltage is either 16 V or the voltage that over time brings the coil to the max. allowed temperature. No Load Current considered.

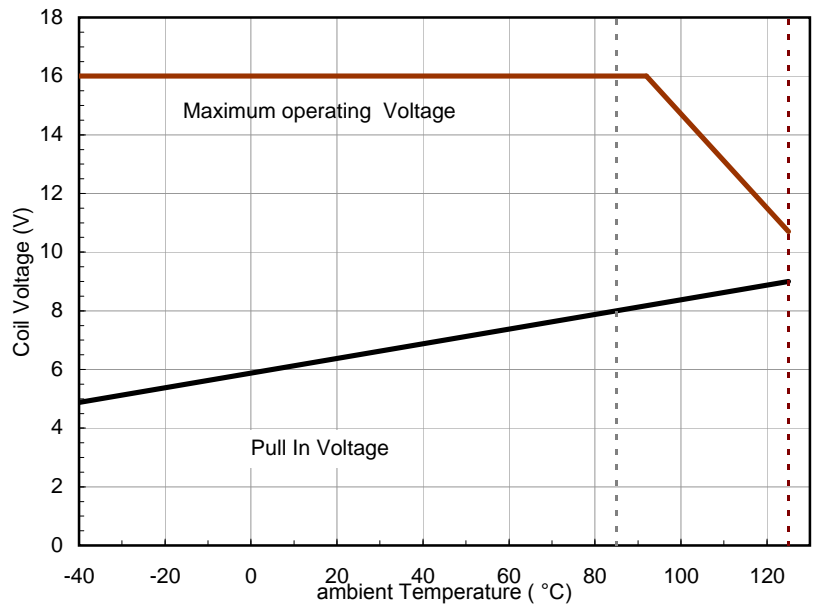

# Taiko Device Techno & Co., Ltd. TB2/HTB2 RELAY SPECIFICATION

All data are at 20°C ambient temperature unless otherwise noted.

## TECHNICAL REFERENCE DATA FOR THE TB2-160 AND HTB2-160 RELAY

### Coil temperature rise

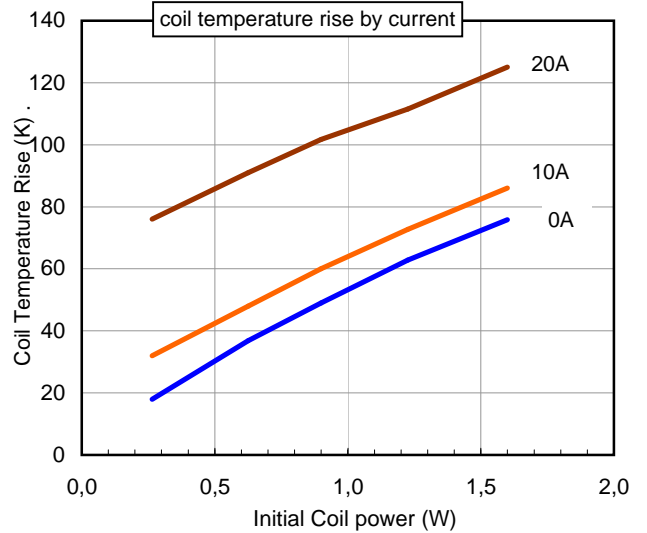
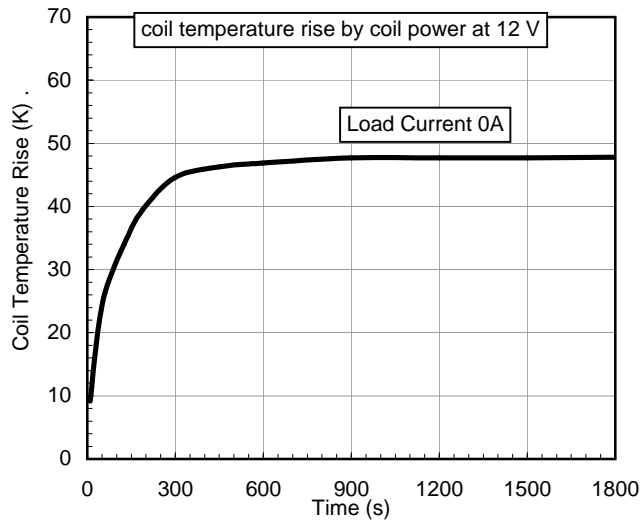

### Over current limit of the TB2-160

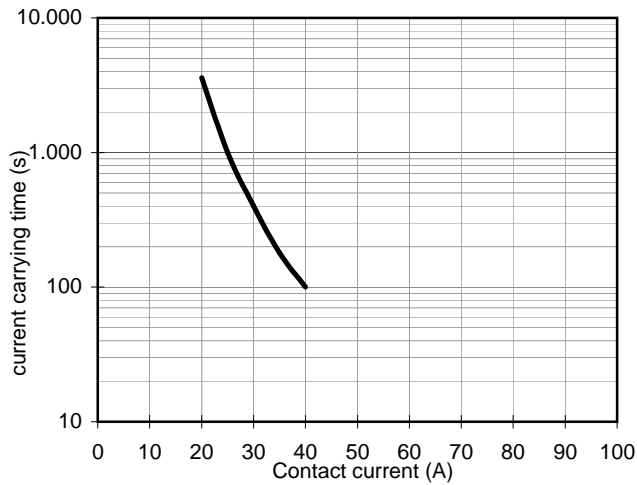

### Operate and Release Time of the TB2-160

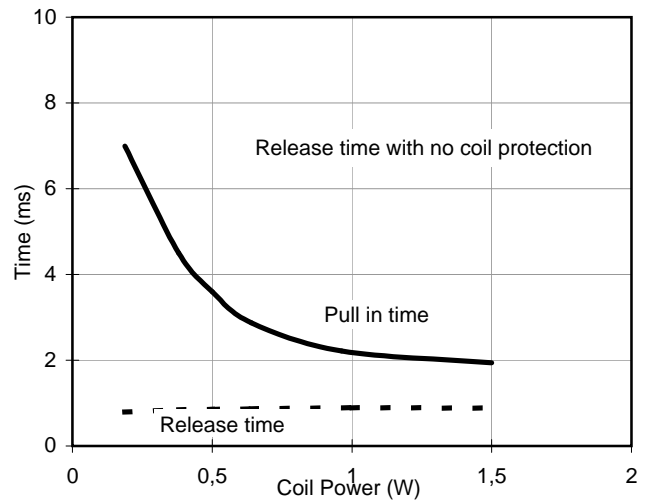

### Contact voltage drop over NO contact of the TB2-160

— increasing current  
- - - decreasing current

This diagram shows the voltage drop over current for the NO contact during the increase of the current and during the decrease

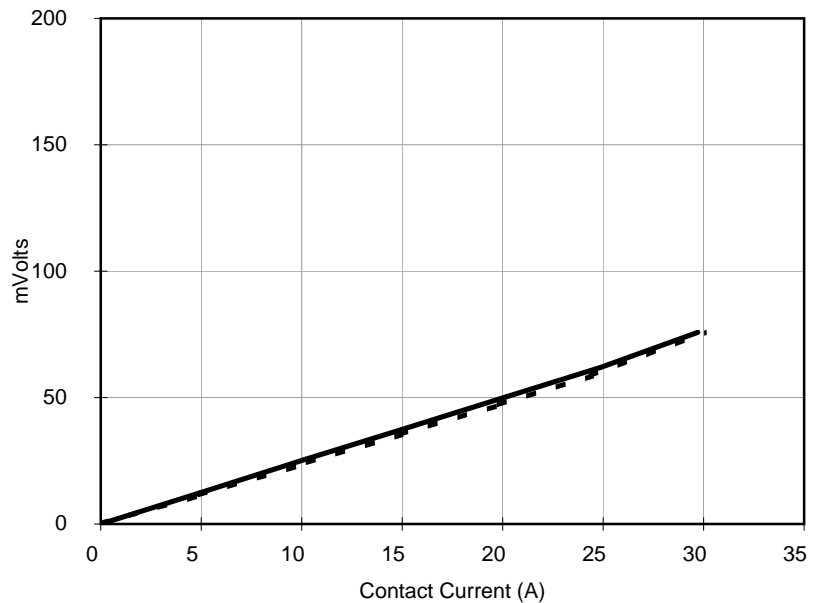

**Taiko Device Techno & Co., Ltd.**  
**TB2/HTB2 RELAY SPECIFICATION**

All data are at 20°C ambient temperature unless otherwise noted.

**External Dimensions / Wiring Diagram / PCB Pin Layout**

**TB2/HTB2**

**Fig.1. External dimensions**

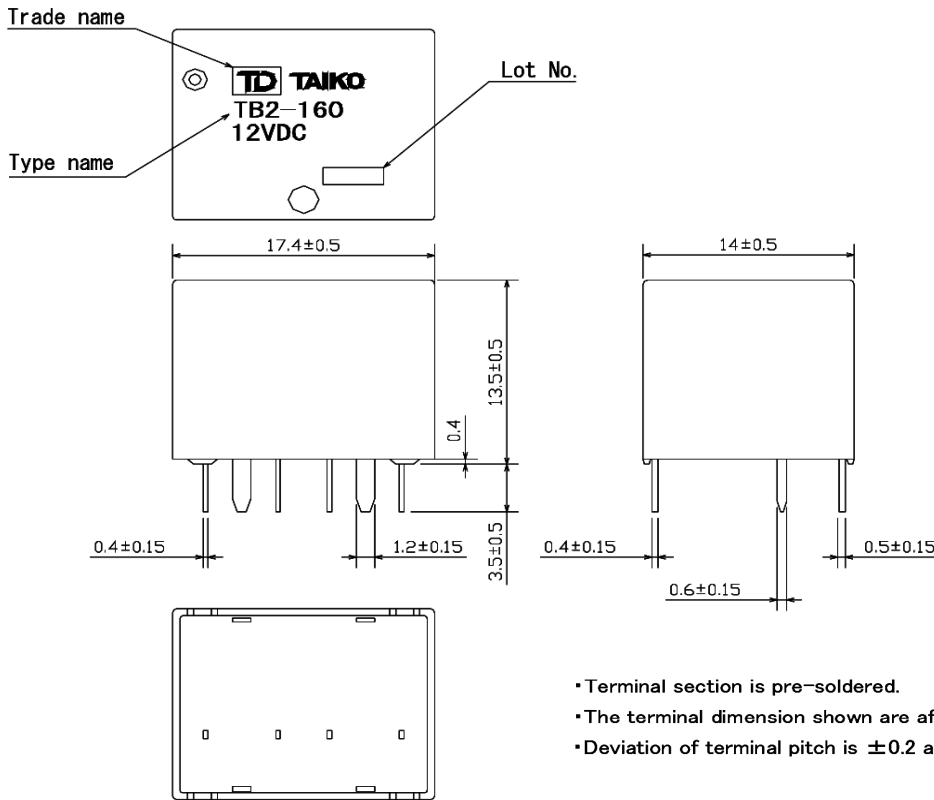

- Terminal section is pre-soldered.
- The terminal dimension shown are after the pre-soldering.
- Deviation of terminal pitch is  $\pm 0.2$  at the root of terminal.

**Fig.2. Wiring diagram (BOTTOM VIEW)**

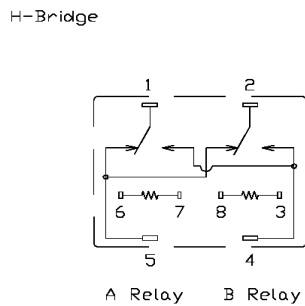

1T × 2 (Separate)

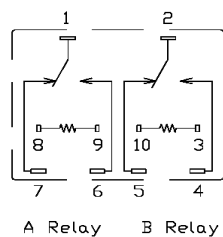

**Fig.3. PCB pin layout (Reference figure) (BOTTOM VIEW)**

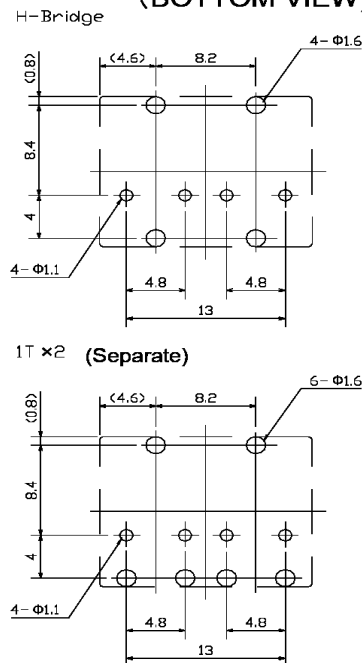

Hole punching tolerance  $\pm 0.1$

**Taiko Device Techno & Co., Ltd.**  
**TB2/HTB2 RELAY SPECIFICATION**

All data are at 20°C ambient temperature unless otherwise noted.

**Packaging specification**

Standard Tube Packaging

25 relays per tube, 40 tubes per box (1000 relays per box)

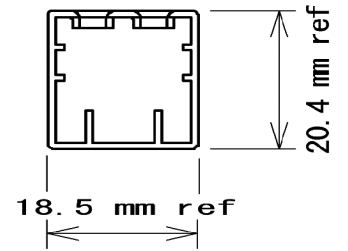
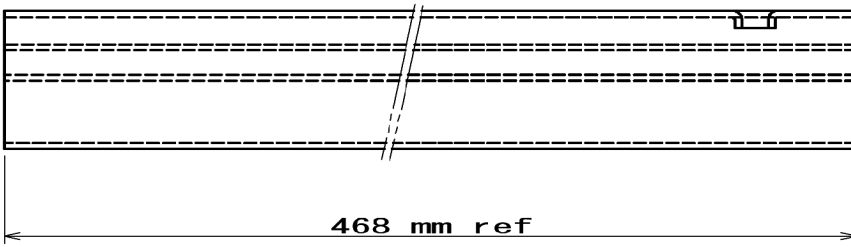

**Notes:**

For further information, please contact Taiko device Techno.

**Disclaimer:**

The above information is for information only and with no responsibility, not binding and can be changed any time.  
Taiko Device Techno cannot be held responsible for typos, or misprints.